



CPF_SPT_01

Transparent sensor

CapaForce© technology
Capacitive + Strain sensor

CONTACT

Phone: +33 582 951 898

Email: contact@nanomade.com

www.nanomade.com

NANOMADE LAB SAS
2 place Pierre Potier
31100 Toulouse, France

SIRET : 87888206700019 | **APE :** 7112B



Transparent CapaForce[®] sensor

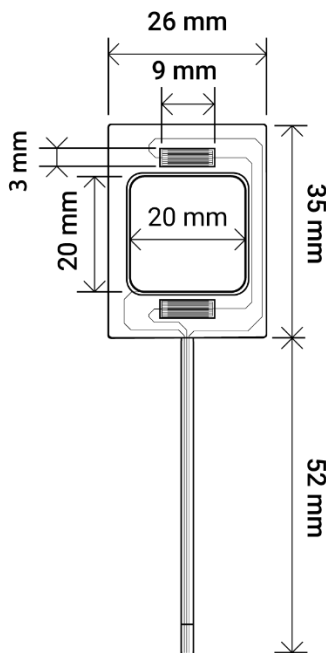
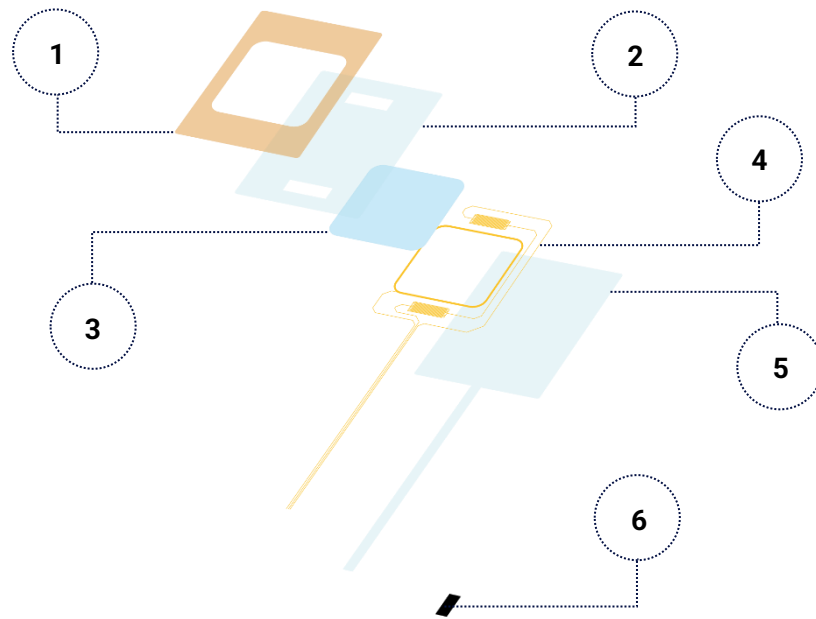

Item	Part	Description
1	Encapsulation layer	Polyimide + Adh - 126 μ m
2	Cover layer	PET + Adh - 50 μ m
3	Capacitive electrode	Transparent conductive ink
4	Strain electrodes + Ink	Copper - 12 μ m
5	Substrate	PET - 125 μ m
6	Stiffener	PET stiffener + Adh - 175 μ m



Specifications

Typical Sensor Properties	Value	Note
Number of strain sensors	1	-
Gauge factor	120	-
Operating voltage	1.8V - 5V	-
Operating current	10 μ A - 500 μ A	-
Current consumption	0.2mA - 0.5mA	-
Nominal sensor resistance	~ 5kOhm	-
Lifetime durability	10M cycles	-
Transparency	80%	-
Environmental stability		
Operating range	-40°C +85°C	
High temperature storage	< +3%	Change in resistance: 85°C for 96 hrs
	< -5%	Change in sensitivity: 85°C for 96 hrs
Low temperature storage	< -10%	Change in resistance: -80°C for 96 hrs
	< -3%	Change in sensitivity: -80°C for 96 hrs
High humidity storage	< +5%	Change in resistance: 85°C/85% RH for 500 hrs
Temperature cycling	< 8%	Change in resistance after 20 cycles +80°C/-40°C